

**Canon**

CANON SOLUTIONS AMERICA

 CANON SEE IMPOSSIBLE



PRINTER  
FORMAT

DETERMINING  
ROI

PRINT HEAD  
TECHNOLOGY

ENVIRONMENTAL  
IMPACT

SERVICE AND  
SUPPORT

CURING SYSTEMS

INK OFFERINGS

# CHOOSING THE RIGHT UV FLATBED PRINTER

A UV Flatbed Buyer's Guide

# A GUIDE TO SELECTING THE MODEL THAT'S RIGHT FOR YOUR BUSINESS

Are you considering adding a UV flatbed printer to your business? Are you a bit perplexed with making the right choice between all the printer models currently available? How do you pick the one that's not only affordable but is also right for your business today and in the future as your business grows tomorrow and beyond?

You've come to the right place. This guide will help you make sense of the complexities of UV flatbed printing technology. Whether your shop already produces large format digital prints or you're looking to add flatbed capability to your existing quick-print, offset, screen printing, packaging, or in-house processes, the goal of this guide is to help you understand the choices you need to make, what to look for when selecting a UV flatbed printer, and how you can calculate your return on investment.

## PRINTER FORMAT: HYBRID/MOVING BED VS. TRUE FLATBED

There are two basic system architectures used in flatbed printing:

### Moving media

The print zone is stationary and the media moves through it just like a roll-to-roll printer. This architecture is found in hybrid printers, often designed primarily for roll media printing but with some rigid printing capability.

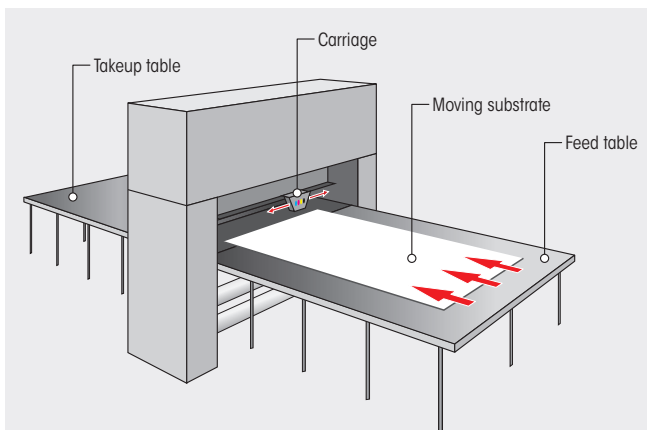

The hybrid design has no moving gantry and instead requires accurately moving the substrate through the printer for the duration of the print.

### True flatbed

The media is held stationary on a table and the printing system moves over the media.

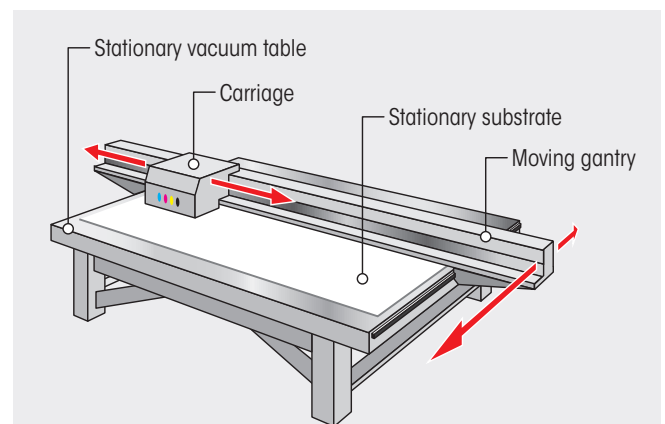

By means of a vacuum table, the true flatbed architecture holds the substrate stationary for the duration of the print cycle while the print head carriage and gantry moves across the media.



## Moving-media architecture (A.K.A. “hybrid” printer)

The majority of low-cost hybrid, moving-media printers on the market were designed as roll-based printers that have been fitted with a belt drive system and/or removable tables to accommodate the transport of rigid media through the stationary printing area. This design was undertaken by printer manufacturers to maximize existing print technologies, enabling them to offer rigid media printing functionality in their current design at a relatively low cost.

### MOVING-MEDIA PRINTER PROS

- Lower capital cost, as the printer requires only modified media handling capabilities and/or accessory tables to allow feeding and exiting rigid media.
- Hybrid printers give shops a 2-for-1: the ability to also print onto roll-based media using the same printer.

### MOVING-MEDIA PRINTER CONS

- Moving the media can result in skewing of the image, requiring a reprint and resulting in unrecoverable time and materials.
- This printer architecture typically uses pinch roller or belt-drive systems that can leave marks on the print, and they often require cleaning of the drive system between prints to remove excess ink.

- Hybrid printers can only print on fairly lightweight media that have at least one 90-degree angle because a corner is required to start feeding the rigid media through the printer. They do poor printing on irregularly shaped or non-square items (unless an additional custom-made jig is used to hold all the pieces in position as they move through the printer), on heavy substrates, or materials that have an uneven surface such as plywood or framed canvas.
- Hybrid printers struggle with achieving sufficient registration for double-sided prints.
- This architecture lacks the geometry required to tile large images over multiple boards, which is a common application for exhibition graphics producers.
- Although the printer footprint can be small, the working area “footprint” is comparatively large, requiring space on both feed and exit sides of the printer.
- Requires more operator intervention while printing to ensure boards do not skew or misfeed.
- Switching between roll-based and rigid-based printing requires physically reconfiguring the system.

## True flatbed architecture

Similar to screen printing, the true flatbed design holds media stationary on a table, and moves the printing system over the rigid substrate. Vacuum tables are often used in true flatbed design, helping ensure that there is no unintended media movement during printing.

## TRUE FLATBED PRINTER PROS

- The print quality is optimized because only the printer is moving while the media is held stationary against a table. This optimizes productivity by providing perfect and repeatable bi-directional alignment and the physical registration (media to image) is optimized, resulting in the highest possible quality images. This is even truer when exotic piezoelectric printing technologies — such as grayscale print heads — are used.
- In addition to any rigid media, the true flatbed architecture enables any reasonably flat object to be printed upon, offering the ability to produce many exotic and unusual applications.
- The true flatbed architecture enables easy edge-to-edge printing (full bleeds), which can reduce finishing time because no further trimming or cutting is required. Printing to pre-finished pieces can also save time and money by eliminating the need to print “overs” to cover the potential damage to a printed piece in the finishing stage.
- Multiple boards can be printed simultaneously by simply placing them on the flatbed. This is useful for smaller sized materials, such as point-of-sale signs that are printed in low quantities.
- Double-sided prints can easily be printed in perfect register.
- Large displays tiled (over several boards) can be printed in perfect alignment so that when assembled, there are no discernible gaps caused by image/media skewing.
- The ability to print on irregularly shaped or non-square items, heavy substrates, unusually smooth media such as glass, or materials that have an uneven surface such as plywood.
- The ability to print on thick substrates such as flat (pre-assembled) furniture, framed canvas, and other manufactured items.
- A single footprint which requires a working space on one side only, for substrate mount/dismount.
- Requires little operator intervention once the device begins printing. Once printing, the operator is freed up to work on other tasks.
- True flatbed systems with a roll media option can quickly switch between roll-based to rigid printing. This can also improve productivity as the rigid substrate can be pre-loaded on the vacuum table during roll-based printing.

## TRUE FLATBED PRINTER CONS

- Initial capital costs can be higher than hybrid printers.
- Roll printing capability is not necessarily built into the system, requiring an optional configuration.

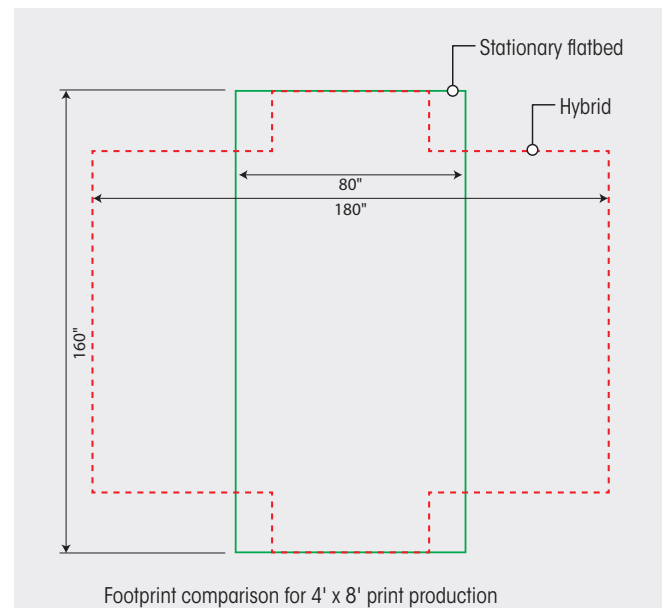

### SIZE FORMATS AND FOOTPRINT REQUIREMENTS

The footprint of a typical hybrid design printer (indicated by the red dashed line) can be considerably larger than that of a typical stationary flatbed design printer (indicated by the green solid line). This can become a significant concern if space is limited.

## Measuring “productivity”

When looking to purchase a new flatbed printer, you will encounter manufacturers’ specification sheets claiming print speeds expressed in square feet per hour or “boards” per hour. These specifications may appear very impressive at first, but are these faster print modes actually producing saleable results as it relates to real world customers? You really need to dig deeper.

The highest print speed is often referred to as “draft mode” which may be useful for producing simple line drawings but may not produce adequate enough quality for many graphics applications or image content. Few devices are able to provide enough ink density at these higher speeds to produce saleable quality, particularly in areas of solid colors.

To evaluate the quality of the available print modes, you should really ask to see a range of test prints of the same image produced across all print modes, e.g. Draft, Production, Quality, Fine Art, etc. Your criteria should be, “What is the fastest speed where I can still sell this?”



Quoted print speeds are calculated using the entire print area—so consider if you are only printing an eight-foot-wide board on a ten-foot-wide printer, your optimization is only going to be 80% of the quoted speed. Additionally, some manufacturers will quote a particular speed but then demonstrate at tradeshow (or produce benchmarks and samples) in unidirectional mode to maximize image quality. Unidirectional printing lays down the ink in only one direction of carriage travel and cuts the quoted productivity in half! Always demand to see the prints produced in bi-directional mode.

There are other factors that impact the real productivity such as the time required to load the board, the time between hitting the print button and the first drop of ink being produced, and finally, the time required to unload the board. This “print cycle” can also vary depending on the design of the printer; for instance, a true stationary flatbed with 2-up, 4 x 8 foot capability allows loading of a second board while the first board is still printing. This means the printer never has to stop printing. The overhead is primarily in the loading for the very first and last board. Other systems featuring hybrid or moving table designs require the print to be nearly or completely printed and unloaded before the next board can be loaded.

Productivity is also not just limited to the printer. Consider what the labor component is to operate the printer. If the operator can hit “print” and then just walk away to perform other tasks, then this can benefit overall shop productivity, allowing for more running time on the device and/or lower labor costs. This is particularly true with the true flatbed design since the substrate is stationary. Accuracy is maintained throughout the print cycle. A hybrid system, on the other hand, generally requires more operator involvement to ensure boards are loading straight and consecutively after the current board completes printing. The operator also has to travel from the front to the back of the printer to load and unload boards.

Additionally, if the device can print onto irregular shaped, pre-cut substrates—easily accomplished with a stationary flatbed—then finished “blanks” can instead be used, which could be cut in advance allowing greater flexibility and cost savings in the workflow. Since finishing mistakes often result in wasted substrate and reprinting, which then reduces net productivity and increases cost.

## SUMMARY

Make sure you’ve done your homework. Go see in person your prints being produced in the various print modes. Insist they be printed bi-directionally. Successively print multiple boards, time it with a stopwatch, and take note of how much media handling the operator performs. Only then can you get an apples-to-apples comparison on real productivity.

## Total cost of application

The system cost of a UV printer should be only one criterion when selecting which printer is right for you. Also consider the total cost of application, which includes the following:

- Capital cost of printer amortized over a three- to five-year period
- Cost of ink, lamps, electricity, and other consumables
- Cost of floor space for printer and workspace
- Consumption rate of ink and other consumables per square foot of production
- Cost of parts and service on an annual basis
- Estimated production volume
- Estimated labor to operate
- Waste due to misprints, overs, and leader for roll printing setup
- Extra finishing costs to trim non full-bleed prints

Understanding the total cost of the application is critical to selling digital printing profitably. The “Calculating ROI” section of this guide looks at the impact that many of these items can make in your overall profitability.

## Conclusion

Your decision on whether to purchase a hybrid-style machine or true flatbed should be driven by the potential for producing as much revenue as possible from a single printer, tempered by the physical space you have or can afford to add. Be sure to ask manufacturers for real-world ROI models that reflect your business considerations.



## DETERMINING THE ROI

UV flatbed printing is a comparatively new technology in relation to established printing technologies such as litho, screen, toner, or even roll-based inkjet printing. For that reason, many print providers considering entering into the flatbed printing segment are rather unsure as to what to expect in regard to costs and profits.

This section is intended to provide insights into how to go about determining the costs to produce graphics, what amount of print volume produced at a specific cost and sold at a particular price is required to pay off the capital investment, and what amount of profit can be realized on a monthly basis beyond that.

### CONSIDERATIONS

An important first step is to understand your local market. The prices charged for graphics and the costs of producing those graphics can vary significantly due to local market conditions. The more research you can do to find out what the going rates are in your area, the more valid are the results generated by an ROI calculator. A good place to start is to request quotes for a variety of applications from the large format print providers in your area as well as pricing for the various substrates purchased from local vendors.

Another variable is the type and complexity of the application being produced and the substrates used—not to mention competition!

There are additional overheads and one-time expenses besides the equipment, ink, and media costs that also need to be considered.

For instance, consider the per square foot cost of your floor space, any building modifications required, the electrical requirements (especially if you also require electrical work to be done), the cost of adequately skilled labor to run the printer, etc.

### CALCULATING ROI

An ROI “calculator” is a common tool that can help determine very quickly how fast you can recoup your investment. A good calculator should be simple to understand yet provide flexibility to enter the wide variety of variables. It can also serve as a tool to determine job costs, cash flow, production time, etc.

The chart on the following page is an example of a typical ROI calculator that may be provided by the manufacturer or can simply be created in Microsoft® Excel®.

On the next page we’ve added explanations of what each line represents. The highlighted text represents user entered data and the values displayed are for demonstration purposes only.

### Conclusion

The ROI calculator is simply a tool and in no way guarantees success in your venture but provides you a means of tracking many of the factors that affect your profitability.

Like with any business, planning, hard work, and most importantly, customers can make all the difference between success and failure.

# SAMPLE ROI CALCULATOR

<b>GROSS REVENUE</b>		
What you would charge for the application	Selling price per square foot	10.00
The hours it would take to print based on the printer speed required to produce saleable quality output	Hours printing per day	3.00
How many business days in a month	Work days per month	20.00
Determined by measuring how fast you can print at the required quality to be able to sell the output	Printer speed (square foot per hour)	194.00
A factor to compensate for wastage due to trimming, reprints, etc.	Sellable/wastage ratio (% of printed media that is sellable)	90%
The gross square footage of printed substrates per day	Total printed media per day including waste (square feet)	582.00
What you will ultimately sell to the end user per day	Sellable output per day (square feet)	523.80
What you would invoice every month based on the assumptions on the preceding lines	<b>Monthly Gross Revenue</b>	<b>104,760.00</b>
<b>MATERIAL COSTS</b>		
This varies by substrate, brand, region, sheet size, etc.	Media cost per square foot (e.g. 3/16" white foam board)	0.27
What the substrate cost is (including waste) to produce all the work above	Total media cost per month	3,142.80
You will need to know the typical ml/square foot of ink usage for the printer and multiply the square footage printed	Ink cost per month (based on 300% coverage)	1,920.60
Conventional UV lamps eventually need replacement. Assuming 500 printing hours of life, the lamp cost per hour can be divided by the number of square feet printed.	UV lamp cost (based on 2 lamps per year)	66.66
	<b>Total Material Costs</b>	<b>5,130.06</b>
<b>OVERHEADS</b>		
This is how much the operator is paid per hour	Labor rate per hour	15.00
How much time the operator spends in addition to the time directly allocated to printing, such as for preparing files, etc. A stationary flatbed allows the operator to typically walk away during the printing and perform other tasks, therefore minimizing any additional overhead.	Labor ratio (# man-hours per 1 printing hour)	1.25
The daily labor cost of the operator directly attributed to printing	Daily labor cost	56.25
Any miscellaneous costs per day that may be required. This could include maintenance items, etc.	Daily additional overhead	0.00
Total labor cost per month	Monthly labor cost	1,125.00
Combined monthly material and labor costs	Total monthly production costs	6,255.06
Your gross profit per month before payments	Gross profit	98,504.94
Maintenance payments you may make per month after the warranty period runs out	Deduct monthly maintenance (zero for year one)	0.00
To keep this ROI simple, we recommend you leave this blank to determine just how many months before the Adjusted Monthly Gross Profit would cover the printer investment. Otherwise, this field could also be used to factor in other fixed monthly expenses such as equipment leases or apportioned building leases, insurance, etc. to help determine what your remaining cash flow would be per month.	Deduct lease payments	0.00
Your net profit after all Material Costs, Overheads and payments are made	<b>Adjusted Monthly Gross Profit:</b>	<b>98,504.94</b>
<b>INVESTMENT AND RETURN</b>		
The bundle price paid for the printing system	Quoted flatbed printer system	96,995.00
If you needed to provide a computer system or other equipment, enter the value here	Computer (customer supplied)	0.00
One additional field to add one-time costs such as for hiring an electrician, carpenter, etc.	Misc.	0.00
	<b>Total Investment</b>	<b>96,995.00</b>
How many months running before you've paid for the system	<b>PAYBACK, IN MONTHS</b>	<b>1.0</b>

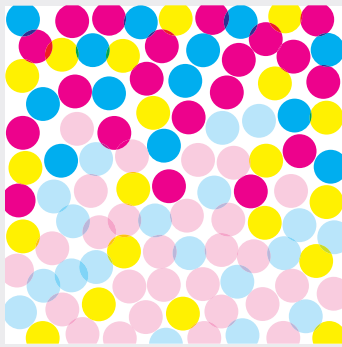

#### CLOSE-UP SIMULATION OF COLOR VIGNETTE USING A SIX-COLOR INK SET AND FIXED DROP SIZE

The use of light magenta and light cyan inks produce smooth quarter-tones and highlights but at the expense of using more ink to cover the media surface to achieve the correct optical density.

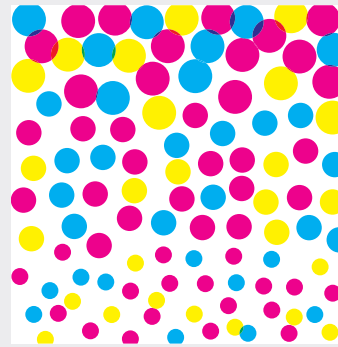

#### CLOSE-UP SIMULATION OF COLOR VIGNETTE USING A FOUR-COLOR INK SET WITH VARIABLE DROP SIZE

The use of smaller ink drop sizes produces quarter-tones and highlights using far less ink than a six-color system to achieve the same optical density.

## PRINT HEAD TECHNOLOGY: GRAYSCALE VS. FIXED DROPLET

Years ago, inkjet manufacturers adopted six color (super-CMYK) printing which added light cyan and light magenta to the standard ink set, substituting the lighter colors for their darker counterparts in the highlights and quarter-tones. This tonal substitution technique was implemented to help overcome the problem of visual graininess inherent in fixed dot, large droplet inkjet technology. The added colors helped produce smoother quarter- and mid-tones and smoother, less grainy gradients. Over time, this complicated and expensive method became the de facto standard, and nearly all inkjet printer manufacturers using fixed dot technology have since adopted six-color printing.

More recently, due to advances in piezoelectric inkjet technology, some printer manufacturers began using grayscale print heads that can produce variable dots by delivering ink droplets that vary in size. By using smaller droplets but placing them closer together, a print head can produce sharp images with smoother gradients and quarter-tones. The ability to jet larger droplets enables the print head to produce uniform, solid colors. The ability to vary the drop size produces images that rival photographic quality.

The volume of an ink drop is typically measured in picoliters (one trillionth of a liter). Generally, the smaller the drop volume, the better. Also, the greater range of multiple drop sizes a print head is able to produce, the better. As a point of reference, a modern desktop inkjet printer like you would have at home produces a four picoliter drop size, allowing it to produce photographic quality images.

Because grayscale printing with smaller ink drops greatly reduces the need for lighter colors to achieve quality results, ink consumption can be immediately reduced by more than 30% on average.

The benefits of light CM inks, duplicate CM ink channels, or additional colors such as green, orange, and violet (Hexachrome) can not be entirely ruled out. They can further improve image quality and color gamut even on today's systems that would otherwise produce excellent CMYK results.

Many printer manufacturers now use some sort of grayscale print technology because of its superior image quality and cost reduction implications for the end user.

### Conclusion

Grayscale print technology is becoming more prevalent because of its ability to deliver better quality prints using less ink, so this part of your decision should be easy. Look for the print technology that will suit the types of prints you produce the most. An array of larger droplets is good if your output mix consists primarily of solid colors. An array of smaller droplets is good if your output mix leans more towards photographic quality. Ideally, the printer you choose should be able to economically produce quality output for the entire range of applications you offer and at a quality level acceptable to your customer.

Use of additional light inks can sometimes produce a better quality image but at an additional cost to you — a cost that the customer might not be willing to pay for.





## OPERATIONAL CONSIDERATIONS

### Ink costs

Ink costs are more than simply the price per liter. How much ink is used per print must also be considered. Only by considering both can you have an accurate notion of the projected costs per square foot. As mentioned in the previous section, because grayscale print heads do not necessarily require the use of lighter colors to achieve quality results, ink usage for a four-color grayscale printer will be less than that of a six-color (or more) fixed-droplet inkjet printer.

One common misperception about the price of UV inks is that they are more expensive compared to solvent inks. On strictly a volume basis, UV inks cost more; however, solvent inks are mostly solvents with only a relatively small amount of pigment. This solvent is volatile and evaporates away in the drying process, leaving a small amount of the pigment behind on the substrate. UV inks have a higher concentration of pigment since they do not need to evaporate but instead “cure” with exposure to high-intensity UV light. As a result, much less UV ink per square foot is jetted onto the substrate, providing considerably greater yield per liter than solvent printing.

A hidden cost with many printers is the amount of ink that is wasted in maintaining proper jetting of the print head nozzles. This “purging” process forces ink through the nozzles in an effort to clear any blockage. On some printers purging will be done on all colors regardless of which color requires it. Other printers purge automatically without any instruction from or

interaction with the operator. This can quickly add up to a significant cost in ink. An ideal ink system will enable the user to select which color to purge and when to purge.

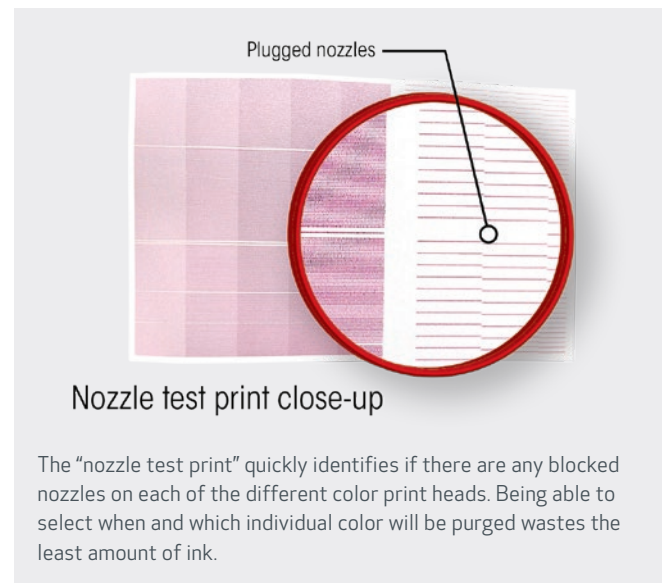

### Power consumption

Rising electricity costs are a reality in today's competitive market. You want to be sure your profits are not being drained by the amount of electricity your printer consumes. Of the models you're considering, check the specifications to see how much wattage and amperage is required. Ideally for a mid-volume system, you'll want to find a printer that uses the more common single-phase power (instead of more energy-consuming three-phase power) and less than 3500 watts of peak power.

In addition to power consumption, you may need to add compressed air. Some printer models require air to drive various systems. If not already in place, a compressed air supply also represents a facility and ongoing operational cost that should be considered.

Most printer manufacturers offer a pre-installation site checklist that you can use during your research to help decide footprint size, printer placement, electrical service adjustments, etc. This is useful to calculate running and potential setup costs before you purchase a printer.

## User maintenance

UV inkjet technology can be less demanding from a maintenance perspective than solvent inkjet technology in that UV inks cure rather than dry. Since UV inks remain liquid until cured by high-intensity UV light, the ink delivery system clogs less frequently and is therefore more reliable. Some user maintenance is still required ranging from daily purging and cleaning to periodic replacement of ink filters, UV lamps, air filters, etc. A simple “nozzle check” can quickly identify if nozzles are blocked and need purging.

## Environmental questions to consider

### ELECTRICAL REQUIREMENTS

- Single- or three-phase power requirement
- Maximum sustained load
- Must it always remain powered on?

### TEMPERATURE REQUIREMENTS

If jetting at ambient temperature, the environment becomes critical in maintaining consistent print quality. Maintaining a consistent ambient temperature, especially in a large, active work space can be difficult and expensive, particularly if costly HVAC systems are required.

### VENTILATION

Requirements vary from office grade ventilation to 20+ room air changes per hour or even stand-alone air treatment systems for some high-volume devices. Given the potential for hazardous levels of uncured, airborne ink particles to be generated by the printer, adequate ventilation is not something to be overlooked.

### RELATIVE HUMIDITY

- Uncontrolled relative humidity of 30% or less greatly increases static electricity on rigid media.
- Low relative humidity can also result in artifacts and reliability issues.
- Some products have active static suppression solutions to counter these effects.

### FOOTPRINT

- Flatbeds are bigger but need no additional space for media handling.
- Belt/pinch systems require an equal board length on each side to allow for media transport, up to 64 square feet of extra space.

### PHYSICAL ENVIRONMENT

Excessively heavy printers or those assembled from components may require rigid flooring such as concrete.

### INSTALLATION RESTRICTIONS

Ensure that the printer can be moved into the printing room, preferably without removing windows or walls.

### CLEANLINESS

Since printing over dust, debris, and fingerprints can produce white specks and other undesirable artifacts on the prints, a clean environment free of airborne dust and debris will greatly reduce the number of wasted or ruined prints plus prolong print head performance. Carpet should be avoided as should placing the printer close to sources of contamination such as routers, woodworking equipment, etc.

## Conclusion

Make good use of any pre-installation planning documents provided by the printer manufacturers.



## SERVICE AND SUPPORT

The printer you buy is a valuable tool of your business. It needs to stay in top shape, and you need to have knowledgeable backup for those (hopefully) few times it isn't running properly. After all, a printer that doesn't run—or doesn't run right—is not making you money, and it may well be costing you money in missed deadlines, upset customers, and extra media/ink costs for job re-runs.

Just as important as choosing the right printer is choosing the right company to back it up. There are many reputable UV flatbed printer manufacturers that may have a limited direct level of service or support. To obtain the highest level of service and support, be sure to research which companies factory train their technicians, and the ongoing training programs that keep their technicians up to date.

Some companies will only service and support just the printer they sold you and are not able or willing to provide training and support for the applications you are trying to produce or the software used in the workflow. This can often lead to great frustration and expense when colors don't reproduce correctly or results are affected by using incorrect substrates. Ideally, your equipment vendor can provide quality training in all aspects of production—from file setup, to color management, to even helping select the best performing substrates for your application.

### Ask the following questions:

1. What is the length of the warranty period and what does it cover?
2. Who services this printer? Technicians employed by the manufacturer? A third-party service organization? A technician working for the local reseller?
3. How are the technicians trained and by whom? Is there ongoing training so they stay up to date?
4. What is the standard response time after I make a call for service?
5. What quality of second level support is provided should there be a delay in fixing the problem?
6. If a part is needed to which the technician doesn't immediately have access, how long will it take to get the part? Where are the parts stocked and how long does it take to get them?
7. If things go well during my warranty period, I may not want to spend money on a service contract once it expires. What are the pros and cons of this?
8. Can I service the printer myself?

### Conclusion

Ensure the technicians servicing your printer are well-trained in all aspects of the print workflow. Use the above set of questions with every printer manufacturer you're considering.





## CURING TECHNOLOGY

Liquid UV curable inks require exposure to high-intensity UV light in order to cure the ink into a solid. This curing process is a reaction initiated by the UV light reacting with chemical photo-initiators in the ink. This sets off a process of polymerization leading to a solidification of the ink, all within a fraction of a second.

The most common UV light source used in flatbed printers have been mercury vapor lamps. Mercury vapor lamps have a broad spectral range with numerous peaks of UV energy. Free radical UV inks are formulated to respond to these multiple peaks, which together provide enough energy to initiate the curing process.

The newest technology now finding its way into the flatbed printer market is UV-LED. This technology shows some promise in that it produces UV with less associated heat byproduct, making it suitable for use with very heat-sensitive media. However, compared to mercury vapor lamps, UV-LED lamps emit a much narrower spectrum of UV energy with single rather than multiple peaks. As a result, ink formulations must be carefully tuned to react properly to these specific wavelengths of UV energy. This sometimes results in ink sets with a considerably smaller color gamut than those inks designed for use with mercury vapor curing systems. The low power and specific wavelength of UV-LED systems also often results in less complete ink curing in the printing zone, leading some manufacturers to offer secondary (offline) curing systems with their printers.

**Comparing the pros and cons of each technology, we can summarize as follows:**

### MERCURY VAPOR PROS

- Lower component cost, which can have an impact on the purchase price of the printer.
- Tried and true lamp technology and ink formulations provide high quality results.
- High degree of curing energy available for complete instant curing and optimized productivity.

### MERCURY VAPOR CONS

- Consume more electricity per square inch of UV output than UV-LED.
- Generate more heat on the media surface, which can cause warping of very heat-sensitive media.

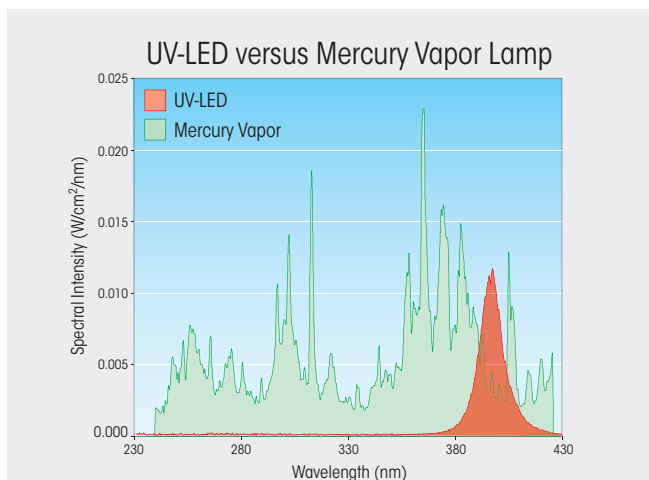

*From: Characterizing the Output and Curing Capabilities of Solid-State UV LED Sources, Paul Mills, Phoseon Technology*

UV inks require photo-initiators tuned to react to the peak wavelengths generated by the UV light source used in the curing system. Traditional mercury vapor technology provides a far greater number of usable frequencies compared to UV-LED, thereby allowing ink companies greater flexibility in developing suitable UV ink formulations.





- Require a warm-up time of 30 to 60 seconds after being switched on to reach optimal output intensity and mechanical shutters to switch light off and on during printing.
- Although inexpensive, lamps require replacement every 500–1000 hours of operation.

### UV-LED PROS

- UV-LED lamps consume considerably less electricity — typically a 50-75% reduction in power consumption compared to mercury vapor lamps.
- Generate less heat on the media surface, enabling easier printing of very heat-sensitive substrates.
- No warm-up time required and can be switched off/on in milliseconds, avoiding the need for mechanical shutters.
- Generally, the average lifespan of a UV-LED lamp is thousands of hours. However, they are typically mounted in arrays that are very expensive to service if they fail.

## INKS—BEYOND JUST CMYK

### White ink, varnish, and more

It is becoming more common with today's UV inkjet printers to offer additional ink channels beyond the four or six process colors. The addition of white ink is by far the most popular spot varnish and has more recently begun increasing in popularity. Both these capabilities deserve consideration as the applications they enable you to do can demand a premium price. Additional channels will undoubtedly lead to new inks such as metallics and spot colors as market demand dictates.

### UV-LED CONS

- UV-LED lamps cost more, subsequently increasing the cost price of the printer.
- Good ink formulations are harder to develop and often result in a smaller color gamut.
- Higher UV-B and UV-C wavelengths can produce “tacky” results in the finish of the cured ink.

### Conclusion

Your decision should fit your business' profile of not only the applications you produce today, but ones you will pursue as new business tomorrow. Be sure the technology you choose can support your needs.

### HOW MUCH OF MY CURRENT WORK COULD USE WHITE INK?

Since most media printed with UV curable inkjet printers, be it rigid or roll-based, is white to begin with, the need for white ink is limited to the realm of specialty applications. Some of these special applications can truly benefit from the digital printing of white, whereas some applications could implement white in a more cost effective manner. It is important to ask yourself some questions before making a purchase decision of a UV printer that features white ink.

If you are producing second surface backlit graphics, it can be less expensive and a more productive approach to manually apply a white flood coat or an adhesive vinyl diffuser than tying up your printer to print white. For more complex applications, if you are applying white by screen printing or cut vinyl, this can become expensive and time consuming, particularly for shorter print runs. Digital printing is generally the same cost from the first print to the last. You may be able to reduce your costs and turnaround times by digitally printing white ink.

### COULD I GET NEW WORK WITH WHITE INK?

Yes. Depending on the application, white ink can make a big difference. Consider the applications that might use non-white material, such as off the shelf rigid building materials, fabrics, packaging materials, manufactured items, etc. Applications on clear substrates are also popular such as backlit displays, window films or even mirrors.

Many uses for white ink are simply limited by a designer's imagination or awareness. By reaching out to creative people and informing them of your new capability, they can design for the device and provide you a competitive edge over the four-color competition.

### WHAT'S THE TREND?

Because the use of white ink has become very popular in recent years, you may want to consider systems that offer a white ink option. Not all systems are equal however. Some printers require you to utilize existing color channels for printing white or varnish—such as light magenta or light cyan. This results in you being able to print white or varnish but now with inferior-looking CMYK results and at the added cost of flushing all the light color inks. Furthermore, the time it takes to switch over inks may take hours of valuable production time.

Varnish is less popular than white ink but when used as a spot varnish can make for a very eye-catching effect that few digital printers can produce.

On the other hand, printing of varnish can be far less productive than CMYK printing and can be easily contaminated by dust and dirt in the environment. This can lead to a higher degree of rejected prints which must be reflected in the final sale price to the end-user.

Another important consideration is that digitally printed varnish is not intended to act as a protective coating. If protection is a requirement, then consider more cost effective, productive ways to apply a flood-coat of varnish or overlamine film using dedicated equipment.

## When shopping for a white ink or varnish capable flatbed, here are some questions to ask:

1. Is white ink or varnish available "on demand" without having to replace/supplant existing color channels such as light cyan and/or light magenta?
2. If I have to switch over to white or varnish, how long will it take and how much ink/flush will I waste?
3. Am I able to print white or varnish at the same time as my other colors, or is it a separate print pass?
4. Can I layer white and colors in any order, and if so, how many layers?
5. How opaque is one layer of white ink?
6. What is the quality of finish in the white ink? Is it really "white" or is it light gray or light yellow?
7. How clear is the varnish? Will it show a tint when printed over top a white substrate?

## Conclusion

Both white ink and varnish capability can help expand your business into areas beyond the ordinary. If you're not sure, check with the various printer manufacturers as some models are field-upgradeable to add white ink or varnish later.



## BEFORE THE PRINT: WHICH RIP TO USE?

The RIP or “raster image processor” is a vital part of the flatbed printing workflow. The RIP at its most basic level takes the computer code that makes up your graphic and translates it into a language your printer understands. Each pixel in your jpeg file or vector coordinates in your PDF are converted to a representative drop of ink on the print.

Taking this another step further, a modern RIP can also process the color information in the file so you can properly color manage the entire process using what’s called an ICC (International Color Consortium) workflow. The ICC workflow uses device “profiles” that characterize the numerous devices in the chain from your digital camera to your image retouching software, to your computer monitor to finally your printer profile. Profiles can either be generated by you, or they are often freely provided by printer and/or media manufacturers. Proper use of ICC profiles ensures the best possible color match from device to device, printer to printer, and location to location. Even more importantly, they can ensure consistency from day to day and operator to operator.

Some RIPs also provide an integrated Pantone® library for spot color matching using the power of the ICC workflow. This means the RIP will automatically pick the closest color match to the spot color used in your file.

A good RIP will also enable you to control your printing workflow so you can accept jobs from your network and direct them to the appropriate printer. Jobs can be intercepted and edited for size, cropping, paneling, etc., before being sent to the printer, and print files can also be archived for later use.

Finally, an RIP will also often process and provide data to support digital finishing solutions in your workflow, such as flexible and rigid media cutting systems. Be sure to understand the capability of the RIP in this regard so that full integration can be achieved with your finishing equipment.

## Things to look for in a good RIP are:

1. Compatibility with your flatbed as well as support for other printers you currently have or plan to have in the future
2. Consistency, predictability, and scalability
3. ICC color management and spot color support including white ink
4. Compatibility with digital cutting solutions
5. Compatibility with the graphics file types you use
6. Network connectivity so others can easily submit jobs through hot folders or virtual printers or even manage the RIP from remote locations
7. Presets that can be saved and applied to subsequent jobs, limiting the amount of operator intervention
8. Processing speed to RIP complex files
9. Multiple printer support
10. Scalability
11. Support

## Conclusion

Some printers are RIP-specific and there are no other RIP software options aside from the one specified by the manufacturer. The upside here is that these RIPs are sometimes finely tuned to work with the specified printer in ways a generic RIP cannot. Also be sure the service technicians or applications specialists for the printer you choose are fully trained on the RIP and can help you with questions on workflow.

The Canon logo is displayed in a bold, red, sans-serif font.

CANON SOLUTIONS AMERICA

**LARGE FORMAT SOLUTIONS**  
100 PARK BLVD., ITASCA, IL 60143

1-800-714-4427 | 1-630-250-6550  
us.info@csa.canon.com **CSA.CANON.COM**